

AM-1424 series

Model AM-1424, AM-1424-E, AM-1424-S, AM-1424-S-E

- Rugged, reliable and heavy duty
- Flow thru bar design - allows for set-ups between bores
- On-site or in-shop operation
- Choice of variable speed or quick-change fixed speed power
- Adjustable mounting system for operator ease
- Remote pendant control
- All B&D boring bars are chrome plated for extra hardness and straightened for improved machining

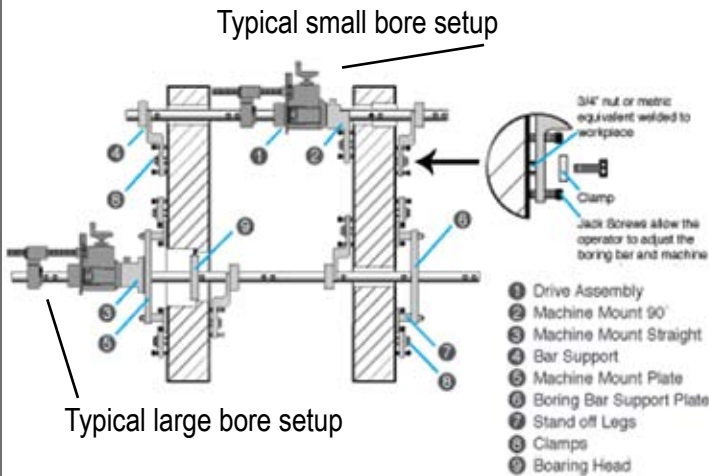

Feature:	AM-1424	AM-1424-E	AM1424-S	AM1424-S-E
Boring range (Standard)	2 ¼" - 16"	2 ¼" - 16"	1 ½" - 16"	1 ½" - 16"
Flow thru bar design	Yes	Yes	Yes	Yes
Boring bar diam.	2"	2"	2", 1 ¼"	2", 1 ¼"
Chrome plated	Yes	Yes	Yes	Yes
Straightened	Yes	Yes	Yes	Yes
Tool ports	½"	½"	½", ⅜"	½", ⅜"
Power choices	Hydraulic Fixed at 35 rpm or 75 rpm Optional power choices: 20 rpm or 120 rpm Model AM1424V: 1.5 110/220V variable Model AM-1424 5Hp: 5Hp 3Ph variable	Electric Infinitely variable from 15-115 rpm	Hydraulic Fixed 35 rpm or 75 rpm Optional power choices: 20 rpm or 120 rpm Model AM1424-S-V: 1.5 110/220V variable Model AM1424-S 5Hp: 5Hp 3Ph variable	Electric Infinitely variable from 15-115 rpm
Direction	Fwd-Neut-Rev	Fwd-Neut-Rev	Fwd-Neut-Rev	Fwd-Neut-rev
Feed	Mechanical	Mechanical	Mechanical	Mechanical
Adjustable mounts	Yes	Yes	Yes	Yes